

Specifications

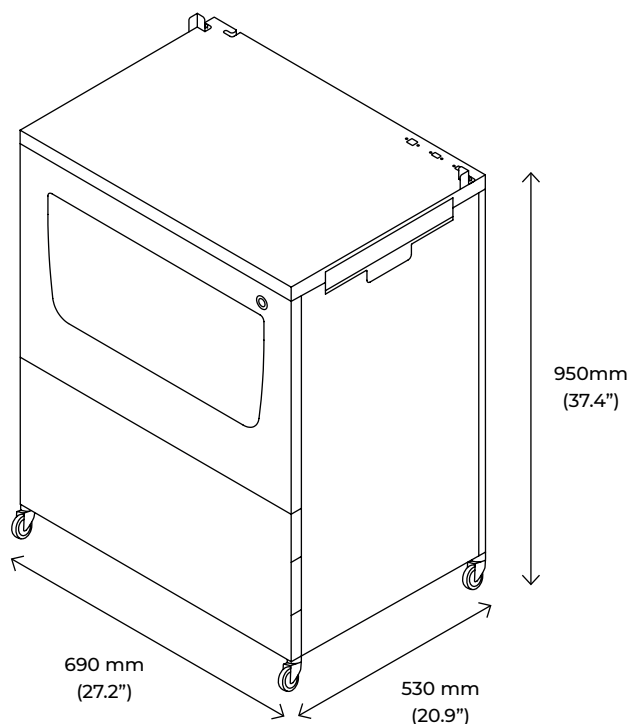

BCN3D Smart Cabinet

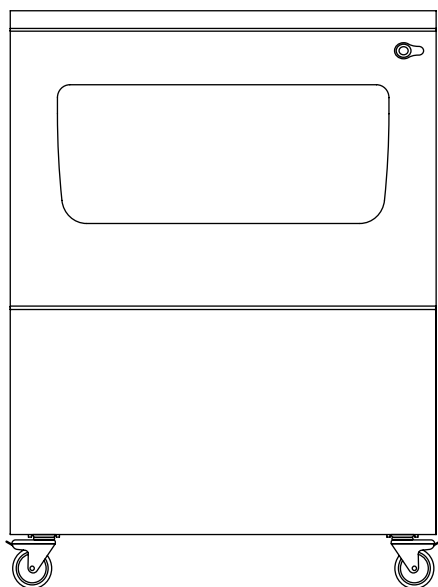

Product properties

Certifications CE / FCC

Physical properties

Overall dimensions 690mm (W) x 530mm (D) x 950mm (H)

Weight 85kg

Shipping box dimensions 800mm (W) x 600mm (D) x 1240mm (H)

Shipping weight 102kg

Shipping method Half Europallet

Specifications



BCN3D Smart Cabinet

Electrical properties

Output	230V / 120V / 100V
Input	version 230V: 200 / 208 / 220 / 230 / 240 V AC [50-60 Hz ±10Hz] version 120V: 100 / 110 / 115 / 120 / 127 V AC [50-60 Hz ±10Hz] version 100V: 100 / 110 / 115 / 120 / 127 V AC [50-60 Hz ±10Hz]
Power output	1000VA
Data connection	USB connection (Type-A to Type-B cable)
UPS topology	Online 1kVA
Battery specifications	3 batteries / 36 VDC x 7Ah
Sensors	Internal and external humidity sensor

Dehumidifier properties

Dehumidifier topology	Air tight container with an active humidity controller unit
Dehumidifier system strategy	4-cycle desiccant and recovery system: First cycle: spool drying Second cycle: stand-by Third cycle: desiccant recovery Fourth cycle: desiccant cool-down
Desiccant type	Alumina base desiccant
Humidity level	< 40% RH
Recovery time (approximate)	2h

Specifications



BCN3D Smart Cabinet

Material handling

Filament diameter	2.85mm
Compatible spools	<p>With BCN3D Spool Cartridge</p> <ul style="list-style-type: none">· Diameter: 197mm - 203mm· Central bore diameter: more than 50mm· Width: 55mm <p>Without BCN3D Spool Cartridge:</p> <ul style="list-style-type: none">· Diameter: up to 303mm· Central bore diameter: more than 50mm· Width: up to 105mm
Number of spools	<p>6 BCN3D Spool Cartridges</p> <p>10 small spools (350/500/750gr.)</p> <p>6 medium spools (1kg.)</p> <p>4 big spools (2.5kg.)</p>
